



**TESTE ANGOLARI REGISTRABILI
ADJUSTABLE ANGLE HEADS**

FORATURA
DRILLING



MASCHIATURA
TAPPING



CARICAMENTO
LOADING



SPECIFICHE TECNICHE TECHNICAL FEATURES

| | | | |
|---|-----------------------|--------------------|------------|
| Modello <i>Type</i> | T20-SK40 | Codice <i>Code</i> | 124936.100 |
| Modello <i>Type</i> | T20-BT40 | Codice <i>Code</i> | 124937.100 |
| Modello <i>Type</i> | T20-CAT40 | Codice <i>Code</i> | 124986.100 |
| Modello <i>Type</i> | T20-HSK63 | Codice <i>Code</i> | 124951.100 |
| Mandrino per pinza <i>Spindle for collet</i> | ER 20 | | |
| Rotazione presa di forza <i>Main drive rotation</i> | SX / LH | | |
| Rotazione mandrino <i>Spindle rotation</i> | DX / RH | | |
| Rapporto di trasmissione <i>Transmission ratio</i> | 1:1 | | |
| Velocità max <i>Max speed</i> | 12000 rpm | | |
| Coppia <i>Torque</i> | 10 Nm | | |
| Spinta max mandrino <i>Spindle max thrust</i> | 350 N | | |
| Peso <i>Weight</i> | 5 Kg | | |
| Lubrificata a grasso <i>Grease lubricated</i> | Klüber Isoflex NBU 15 | | |

OPZIONI OPTIONS

| | |
|--|------------|
| Pinza ER20 DIN 6499/B <i>ER20 collet DIN 6499/B</i> | 411220.100 |
| Pinza di maschiatura ET-1-20 con compensazione <i>Tapping collet ET-1-20 with compensation</i> | 401220.200 |
| Pinza di maschiatura ER20 con quadro <i>Tapping collet ER20 with square</i> | 411220.200 |
| Mandrino Weldon | |
| Mandrino ABS licenza Komet® | |
| Perno interasse 80 mm <i>Pin pitch 80 mm</i> | |

DOTAZIONE STANDARD STANDARD EQUIPMENT

| | |
|--|------------|
| Stop-block standard <i>Standard stop-block</i> | 311201.025 |
| Chiave <i>Clamping wrench</i> | |
| Tubetto di grasso <i>Grease tube</i> | |
| Bauletto <i>Storage case</i> | |

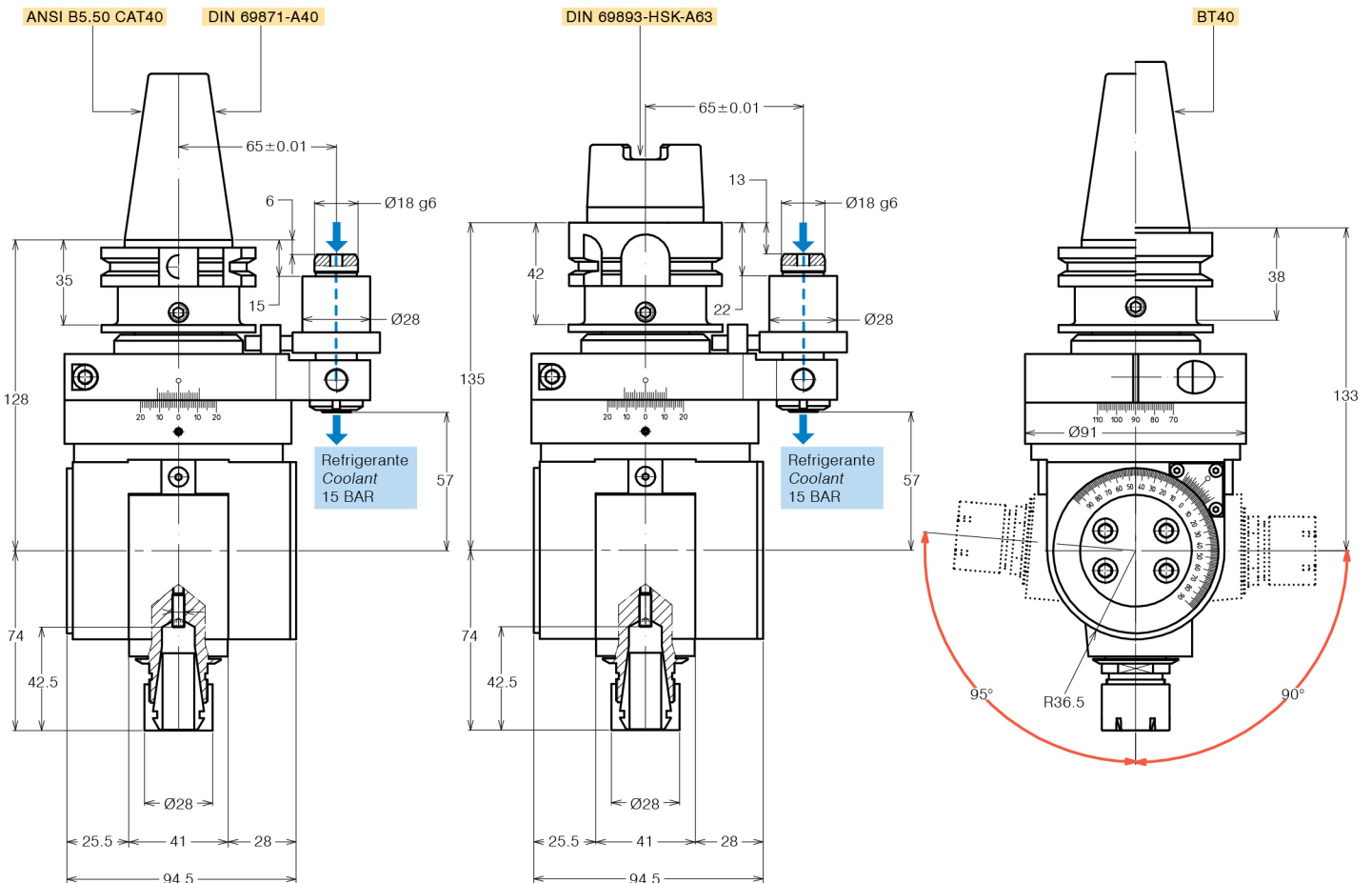



TESTE ANGOLARI REGISTRABILI
ADJUSTABLE ANGLE HEADS

FORATURA
DRILLING



MASCHIATURA
TAPPING



CARICAMENTO
LOADING



SPECIFICHE TECNICHE TECHNICAL FEATURES

| | | | |
|---|-----------------------|--------------------|------------|
| Modello <i>Type</i> | T25-SK40 | Codice <i>Code</i> | 124961.100 |
| Modello <i>Type</i> | T25-BT40 | Codice <i>Code</i> | 124962.100 |
| Modello <i>Type</i> | T25-CAT40 | Codice <i>Code</i> | 124963.100 |
| Modello <i>Type</i> | T25-HSK63 | Codice <i>Code</i> | 124964.100 |
| Mandrino per pinza <i>Spindle for collet</i> | ER 25 | | |
| Rotazione presa di forza <i>Main drive rotation</i> | SX / LH | | |
| Rotazione mandrino <i>Spindle rotation</i> | DX / RH | | |
| Rapporto di trasmissione <i>Transmission ratio</i> | 1:1 | | |
| Velocità max <i>Max speed</i> | 5000 rpm | | |
| Coppia <i>Torque</i> | 13 Nm | | |
| Spinta max mandrino <i>Spindle max thrust</i> | 500 N | | |
| Peso <i>Weight</i> | 5 Kg | | |
| Lubrificata a grasso <i>Grease lubricated</i> | Klüber Isoflex NBU 15 | | |

OPZIONI OPTIONS

| | |
|--|------------|
| Pinza ER25 DIN 6499/B <i>ER25 collet DIN 6499/B</i> | 411225.100 |
| Pinza di maschiatura ET-1-25 con compensazione <i>Tapping collet ET-1-25 with compensation</i> | 401225.200 |
| Pinza di maschiatura ER25 con quadro <i>Tapping collet ER25 with square</i> | 411225.200 |
| Mandrino Weldon | |
| Mandrino ABS licenza Komet® | |
| Mandrino DIN 69893-HSK | |
| Perno interasse 80 mm <i>Pin pitch 80 mm</i> | |

DOTAZIONE STANDARD STANDARD EQUIPMENT

| | |
|--|------------|
| Stop-block standard <i>Standard stop-block</i> | 311201.025 |
| Chiave <i>Clamping wrench</i> | |
| Tubetto di grasso <i>Grease tube</i> | |
| Bauletto <i>Storage case</i> | |

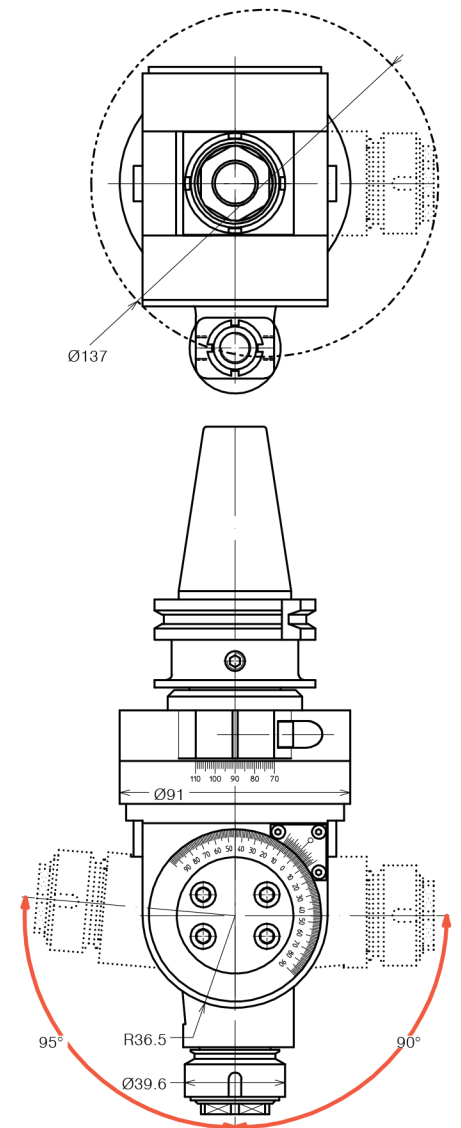
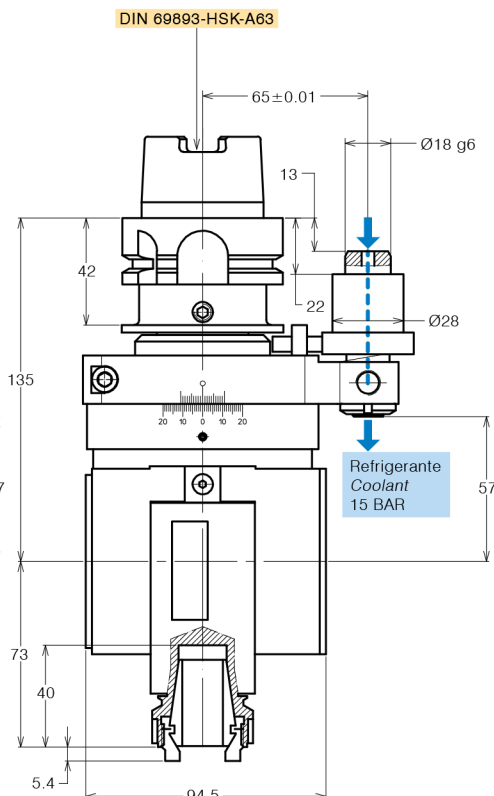
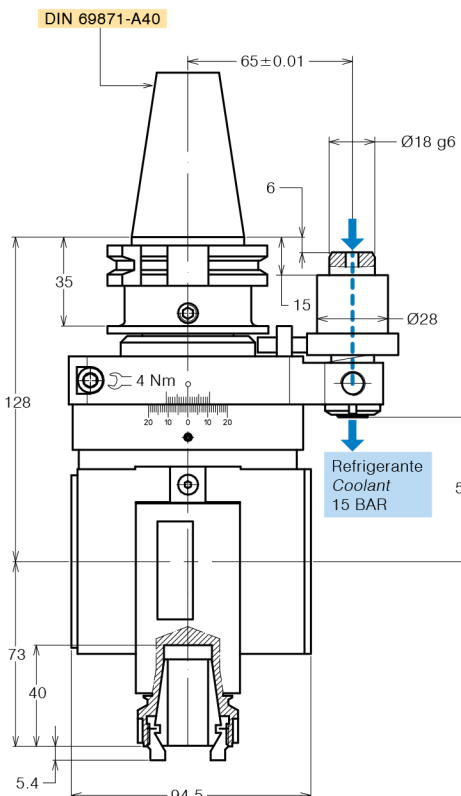



TESTE ANGOLARI REGISTRABILI
ADJUSTABLE ANGLE HEADS

FORATURA
DRILLING



MASCHIATURA
TAPPING



CARICAMENTO
LOADING



SPECIFICHE TECNICHE TECHNICAL FEATURES

| | | | |
|---|-----------------------|--------------------|------------|
| Modello <i>Type</i> | T25-SK50 | Codice <i>Code</i> | 124907.100 |
| Modello <i>Type</i> | T25-BT50 | Codice <i>Code</i> | 124913.100 |
| Modello <i>Type</i> | T25-CAT50 | Codice <i>Code</i> | 124991.100 |
| Modello <i>Type</i> | T25-HSK100 | Codice <i>Code</i> | 124952.100 |
| Mandrino per pinza <i>Spindle for collet</i> | ER 25 | | |
| Rotazione presa di forza <i>Main drive rotation</i> | DX / RH | | |
| Rotazione mandrino <i>Spindle rotation</i> | DX / RH | | |
| Rapporto di trasmissione <i>Transmission ratio</i> | 1:1 | | |
| Velocità max <i>Max speed</i> | 4000 rpm | | |
| Coppia <i>Torque</i> | 16 Nm | | |
| Spinta max mandrino <i>Spindle max thrust</i> | 1000 N | | |
| Peso <i>Weight</i> | 13 Kg | | |
| Lubrificata a grasso <i>Grease lubricated</i> | Klüber Isoflex NBU 15 | | |

OPZIONI OPTIONS

| | |
|--|------------|
| Pinza ER25 DIN 6499/B <i>ER25 collet DIN 6499/B</i> | 411225.100 |
| Pinza di maschiatura ET-1-25 con compensazione <i>Tapping collet ET-1-25 with compensation</i> | 401225.200 |
| Pinza di maschiatura ER25 con quadro <i>Tapping collet ER25 with square</i> | 411225.200 |
| Mandrino Weldon | |
| Mandrino ABS licenza Komet® | |
| Mandrino DIN 69893-HSK | |
| Perno interasse 110 mm <i>Pin pitch 110 mm</i> | |

DOTAZIONE STANDARD STANDARD EQUIPMENT

| | |
|--|------------|
| Stop-block standard <i>Standard stop-block</i> | 311201.025 |
| Chiave <i>Clamping wrench</i> | |
| Tubetto di grasso <i>Grease tube</i> | |
| Bauletto <i>Storage case</i> | |

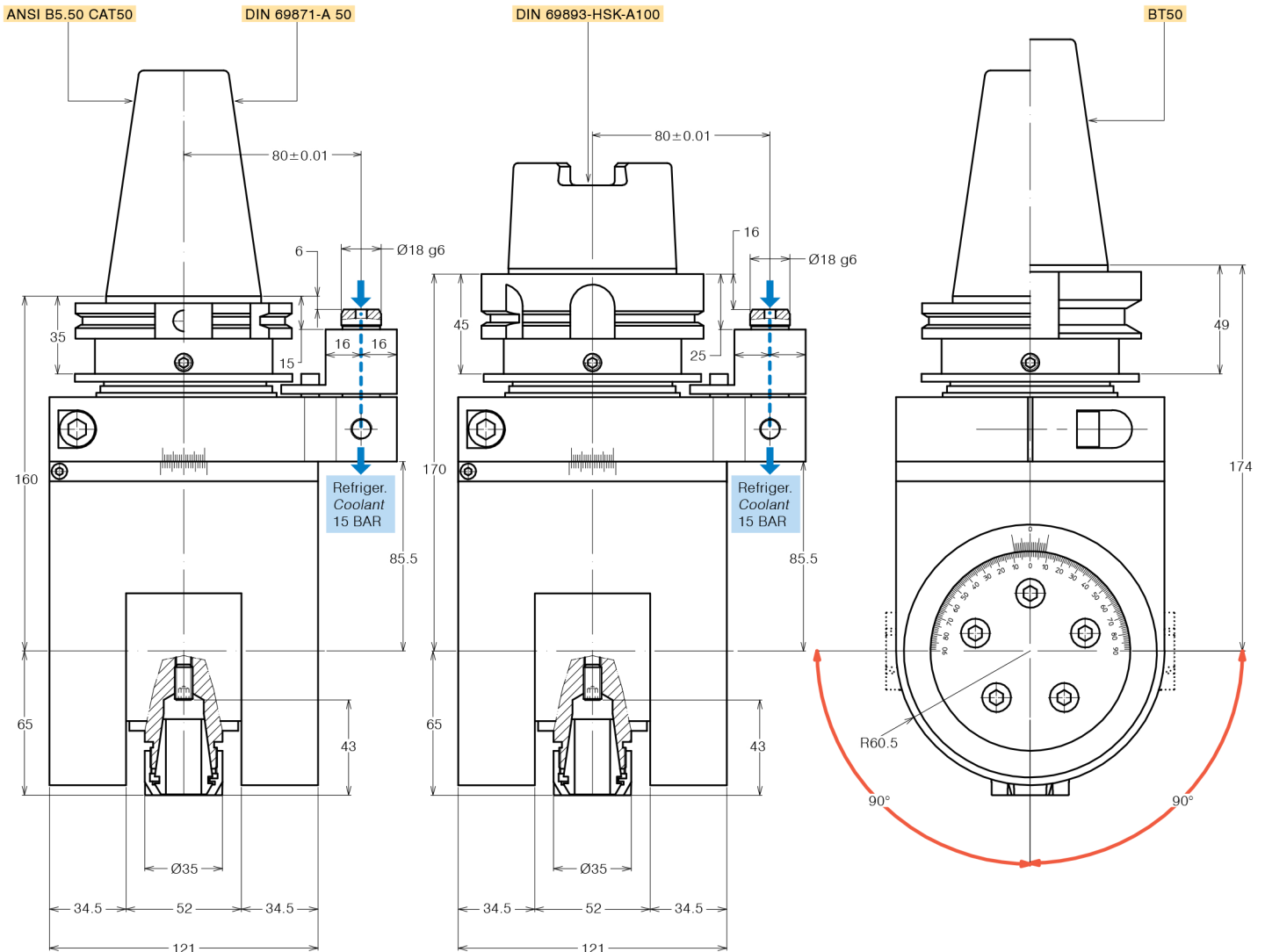



**TESTE ANGOLARI REGISTRABILI
ADJUSTABLE ANGLE HEADS**

FORATURA
DRILLING



MASCHIATURA
TAPPING



CARICAMENTO
LOADING



SPECIFICHE TECNICHE TECHNICAL FEATURES

| | | | |
|---|-----------------------|--------------------|------------|
| Modello <i>Type</i> | T32-SK50 | Codice <i>Code</i> | 124910.100 |
| Modello <i>Type</i> | T32-BT50 | Codice <i>Code</i> | 124914.100 |
| Modello <i>Type</i> | T32-CAT50 | Codice <i>Code</i> | 124987.100 |
| Modello <i>Type</i> | T32-HSK100 | Codice <i>Code</i> | 124930.100 |
| Mandrino per pinza <i>Spindle for collet</i> | ER 32 | | |
| Rotazione presa di forza <i>Main drive rotation</i> | DX / RH | | |
| Rotazione mandrino <i>Spindle rotation</i> | DX / RH | | |
| Rapporto di trasmissione <i>Transmission ratio</i> | 1:1 | | |
| Velocità max <i>Max speed</i> | 3000 rpm | | |
| Coppia <i>Torque</i> | 30 Nm | | |
| Spinta max mandrino <i>Spindle max thrust</i> | 1200 N | | |
| Peso <i>Weight</i> | 17 Kg | | |
| Lubrificata a grasso <i>Grease lubricated</i> | Klüber Isoflex NBU 15 | | |

OPZIONI OPTIONS

| | |
|--|------------|
| Pinza ER32 DIN 6499/B <i>ER32 collet DIN 6499/B</i> | 411232.100 |
| Pinza di maschiatura ET-1-32 con compensazione <i>Tapping collet ET-1-32 with compensation</i> | 401232.200 |
| Pinza di maschiatura ER32 con quadro <i>Tapping collet ER32 with square</i> | 411232.200 |
| Mandrino Weldon | |
| Mandrino ABS licenza Komet® | |
| Mandrino DIN 69893-HSK | |
| Perno interasse 110 mm <i>Pin pitch 110 mm</i> | |

DOTAZIONE STANDARD STANDARD EQUIPMENT

| | |
|--|------------|
| Stop-block standard <i>Standard stop-block</i> | 311201.025 |
| Chiave <i>Clamping wrench</i> | |
| Tubetto di grasso <i>Grease tube</i> | |
| Bauletto <i>Storage case</i> | |

