

drilling units

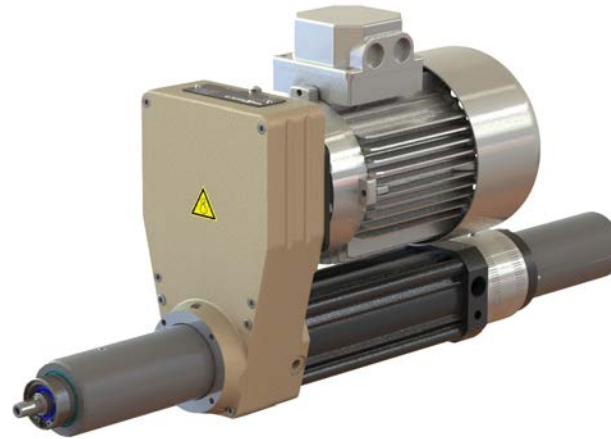

unità di foratura

DU10P.50	
Feed Avanzamento	pneumatic pneumatico
Stroke Corsa	50 mm 50 mm
Drilling Capacity Capacità di foratura	ø10 on steel Rm50 ø10 su acciaio Rm50
Thrust at 6 bar Spinta a 6 bar	1200 N 122 Kg
Spindle speed Velocità mandrino	from 500 to 9000 rpm da 500 a 9000 g/l'
Motor Power Potenza Motore	from 0.37 to 1.1 Kw da 0.37 a 1.1 Kw



- Pneumatic cylinder ø63.
- Air inlet (1) G1/8.
- Air consumption 1,10NL/cycle.
- Spindle concentricity 0,01.
- Electric wires connections M16x1,5 (2).
- Internal limit switches (3)
Optional: pneumatic limit switches
or inductive sensors.
- Feed hydrocheck (5) in line with spindle.
Optional: peck feed hydrocheck.
- Fast/slow stroke separately adjustable
(4) with mechanical stop.
- Standard color: Beige RAL 1001.
Other colors on request.
- Weight from 15 to 22 Kg



- Cilindro pneumatico ø63.
- Ingressi aria (1) G1/8.
- Consumo aria 1,10NL/ciclo.
- Concentricità mandrino 0,01.
- Ingresso cavi elettrici M16x1,5 (2).
- Fine corsa di posizione elettrici interni (3)
Su richiesta fine corsa pneumatici o
sensori induttivi.
- Regolatore idraulico di avanzamento (5)
in linea con il mandrino.
Su richiesta regolatore per scarico
truciolo.
- Corse rapido/lento regolabili
separatamente (4) con battuta meccanica.
- Colore standard: Beige RAL 1001.
Altri colori su richiesta.
- Peso da 15 a 22 Kg

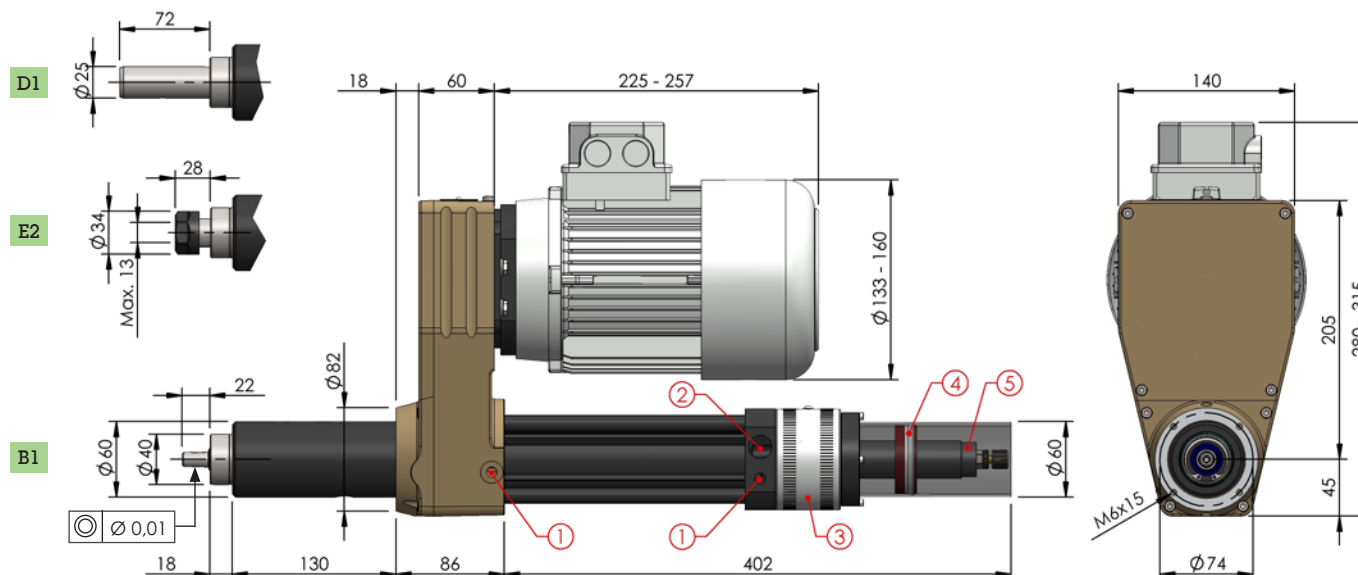

DU10P 50

stroke / corsa

	spindle / mandrino
B1	B12 DIN 238
E2	ER20 DIN 6499
D1	ø16 DIN 55058

	rpm	
	50Hz	60Hz
05	500	600
07	750	900
10	1000	1200
12	1250	1500
15	1500	1800
20	2000	2400
25	2500	3000
30	3000	3600
50	5000	6000
70	7000	8400
90	9000	10800

	motor / motore
036	80 B14 0,37Kw 6 poles
056	80 B14 0,55Kw 6 poles
076	80 B14 0,75Kw 6 poles
034	71 B14 0,37Kw 4 poles
054	80 B14 0,55Kw 4 poles
074	80 B14 0,75Kw 4 poles
032	71 B14 0,37Kw 2 poles
052	71 B14 0,55Kw 2 poles
072	80 B14 0,75Kw 2 poles
112	80 B14 1,10Kw 2 poles

	motor type / tipo motore
S	230-400V-50/60Hz
A	brake motor autofrenante
V	forced ventilation servovenilato
AV	brake motor + forced ventilation autofrenante + servovenilato

	hydrocheck / regolatore
45H	standard
45HS	with oil bowl con serbatoio olio
75HP	peck feed scarico trucioli

STANDARD COLOR



OPTIONAL COLORS

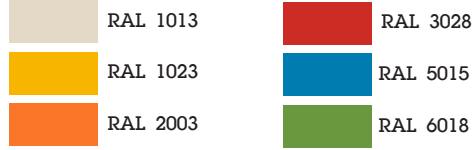

optional :

accessories for easy installation
accessori per una facile installazione

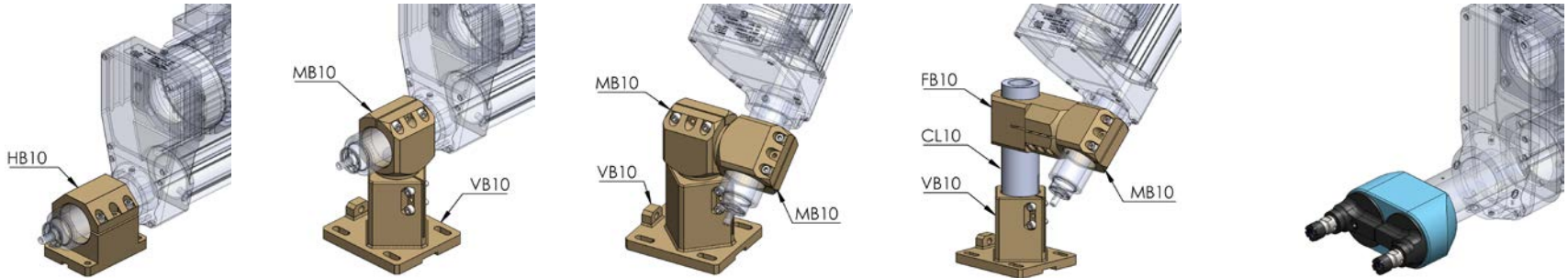

multispindle head
teste multiple